



Series PD-10LHP

Piezoresistive OEM differential pressure transducers with optimum stability

Features

- Optimum long-term stability
- Robust stainless-steel housing
- Front-flush, crevice-free welded diaphragm
- Very high overload resistance
- High line pressure up to 600 bar
- Optimised thermal behaviour

Technology

- Insulated piezoresistive pressure sensor encapsulated in an oil-filled metal housing
- Ideal for mounting with O-ring
- Typical range of output signal of 160 mV / mA

Typical Applications

- OEM
- Industry
- Laboratory



Accuracy

$\pm 0,25$ %FS

Long-term Stability

$\pm 0,15$ %FS/year

Pressure Ranges

0...0,1 bar to 0...30 bar



Series PD-10LHP

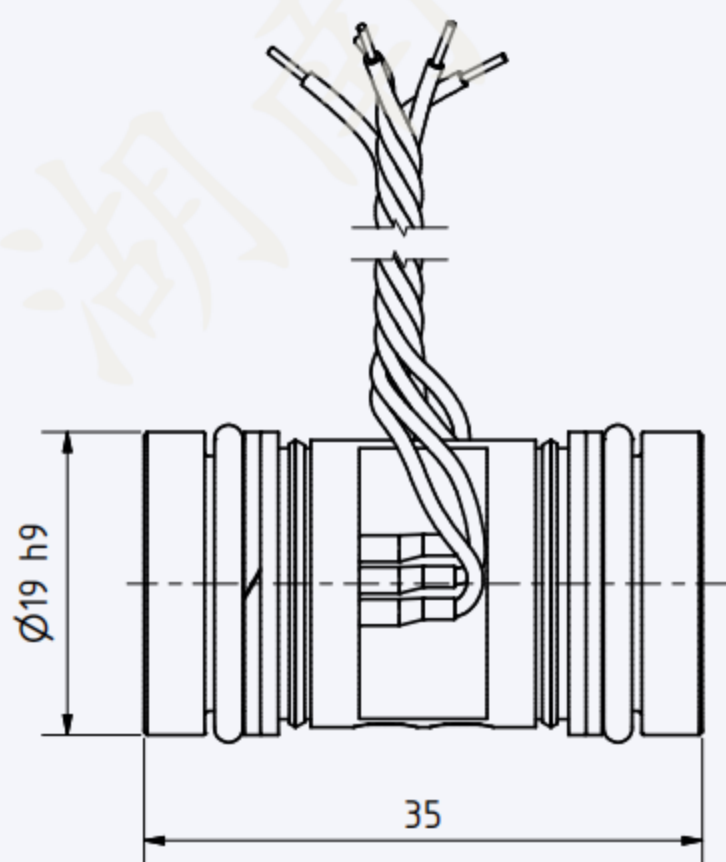
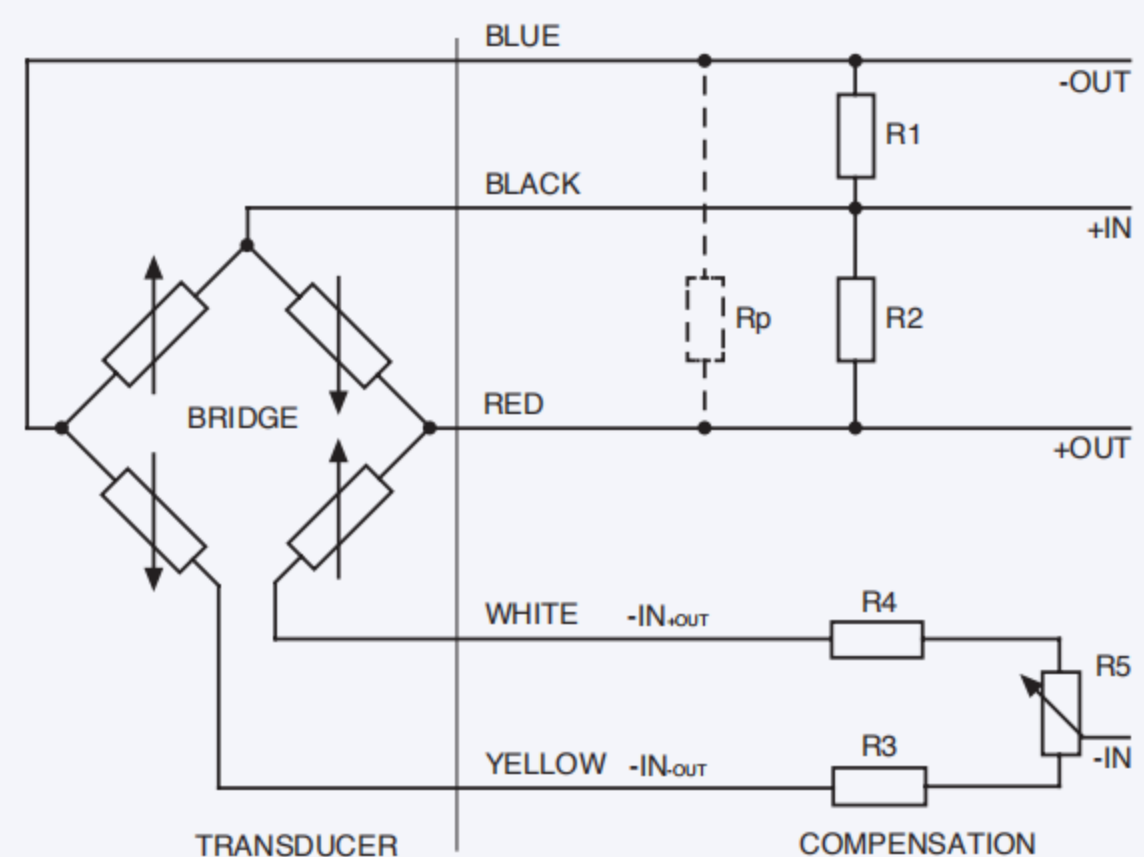

Diagram of a measurement bridge with compensation





Series PD-10LHP – Specifications

Standard Pressure Ranges

Differential pressure		Overload resistance positive	Overload resistance negative	Sensitivity		
PD				min.	typ.	max.
-0,1...0,1	0...0,1	5	2,5	98	130	163
-0,3...0,3	0...0,3					
-1...1	0...1	15	7,5	40	53	66,7
	0...3	15	7,5	40	53	66,7
	0...10	50	25	12	16	20
	0...30	120	60	4	5,3	6,7
bar diff.		bar		mV / (mA x bar)		
Zero point at zero differential pressure		With reference to zero				

Performance

Accuracy @ RT (20...25 °C)	$\pm 0,25$ %FS typ.	Non-linearity (BFSL), pressure hysteresis, non-repeatability
	$\pm 0,50$ %FS max.	
Offset @ RT (20...25 °C)	$< \pm 25$ mV / mA	Uncompensated
	$< \pm 2$ mV / mA	Compensated with R3 or R4
Long-term stability	$\leq \pm 0,15$ %FS	For pressure ranges > 1 bar, per year under reference conditions
	$\leq \pm 1,5$ mbar	For pressure ranges ≤ 1 bar, per year under reference conditions
Line pressure	≤ 600 bar	
Line pressure dependency	$< 0,01$ mV / bar	For pressure ranges ≥ 1 bar
	$< 0,02$ mV / bar	For pressure ranges < 1 bar
Position dependency	≤ 5 mbar	Calibrated in vertical installation position with metal diaphragm (+) side facing downwards
Temperature coefficient zero TCzero pre-compensated with R1 or R2	$\leq \pm 0,015$ %FS / K	For pressure ranges ≥ 3 bar
	$\leq \pm 0,45$ mbar / K	For pressure ranges < 3 bar
Temperature coefficient sensitivity TCsens	$\leq \pm 0,06$ % / K	For pressure ranges ≥ 1 bar
	$\leq \pm 0,12$ % / K	For pressure ranges < 1 bar
Temperature coefficient total bridge resistance TC-resistance	1800...3000 ppm / K	



Series PD-10LHP – Specifications

Temperature Ranges

Compensated temperature range	-10...80 °C	Optional: Temperature ranges within -55...150 °C possible
Media temperature range	-40...125 °C	
Ambient temperature range	-40...125 °C	
Storage temperature range	-40...125 °C	

Electrical Data

Half-open measurement bridge

Constant current supply	1 mA nominal 3 mA max.	
Bridge resistance @ RT (20...25 °C)	3,5 kΩ ± 20 %	
Electrical connection	Silicone wires AWG22 L = 100 mm	Optional: other lengths on request
Insulation	> 100 MΩ @ 500 VDC	

Mechanical Data

Materials in contact with media

Housing and diaphragms	Stainless steel AISI 316L	Optional: Hastelloy
Seal ring at 600 bar line pressure	FKM (75 Shore) ø 15 mm × 2 mm -20...200 °C	Optional: other materials on request
Support ring	PTFE	Optional: PEEK

Other materials

Pressure transducer oil filling	Silicone oil	Optional: other oil fillings on request
---------------------------------	--------------	---

Further details

Diameter × height	ø 19 mm × 35 mm, see Dimensions and options
Weight	approx. 55 g

Dynamics

Vibration resistance	20 g, 10...2000 Hz, ± 10 mm	IEC 60068-2-6
Shock resistance	50 g, 11 ms	IEC 60068-2-27
Natural frequency (resonance)	> 30 kHz	
Endurance @ RT (20...25 °C)	> 10 million pressure cycles	0...100 %FS
Dead volume change @ RT (20...25 °C)	< 10 mm ³	



Series PD-10LHP – Dimensions and Options

Overview of Versions

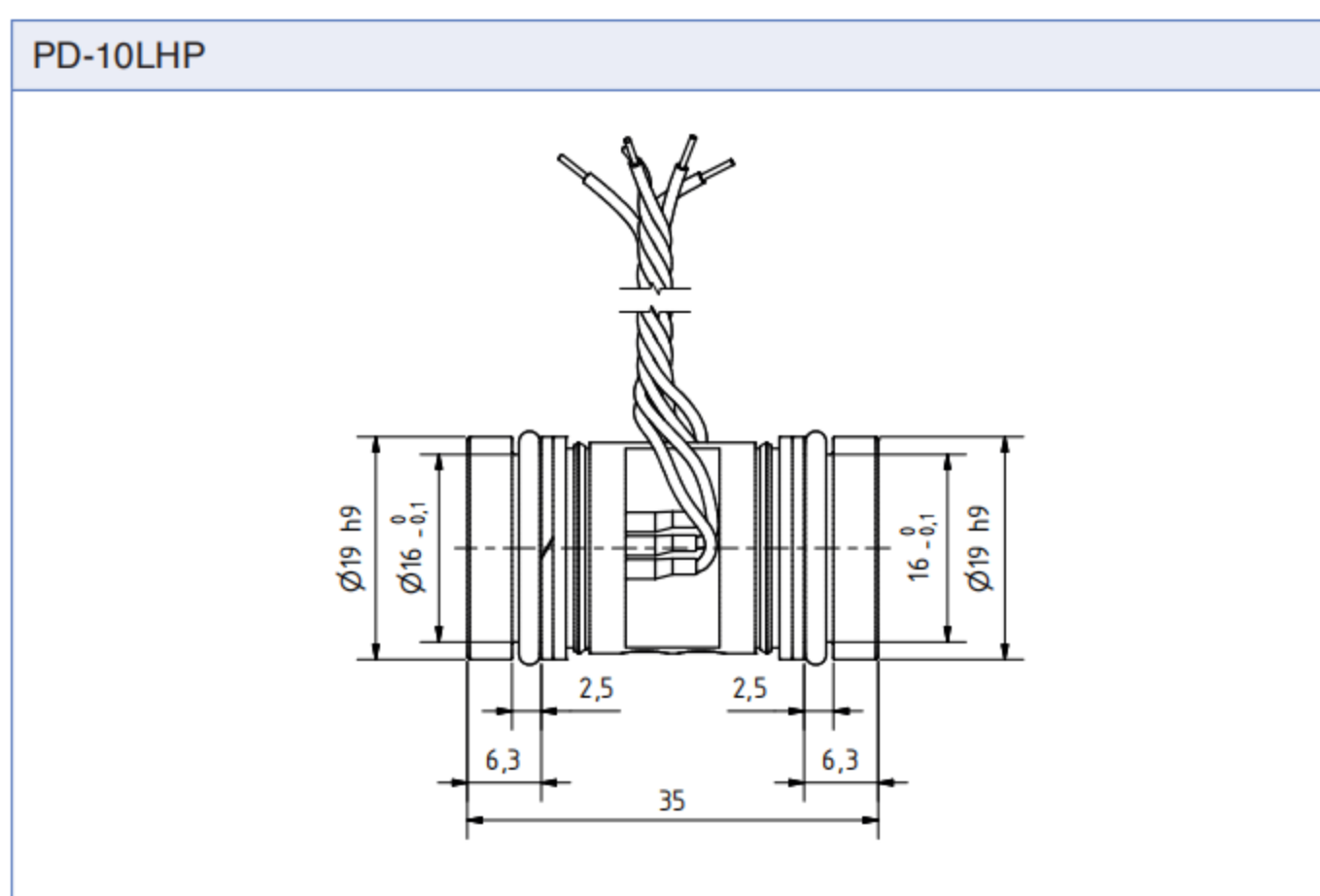

Electrical Connection

Half-open measurement bridge pin assignment		
Label	Designation	Wire colour
+OUT	Pos. Output	red
+IN	Pos. Supply	black
-OUT	Neg. Output	blue
-IN _{-OUT}	Neg. Supply (half bridge -OUT)	yellow
-IN _{+OUT}	Neg. Supply (half bridge +OUT)	white

Overview of Customer-specific Options

- Analysis for other pressure ranges
- Analysis for other temperature ranges
- Analysis with a mathematical compensation model
- Housing and diaphragm made of Hastelloy
- Seal rings made of other materials
- Other oil filling types for pressure transducers: e.g. special oils for oxygen applications
- Modifications to customer-specific applications

Examples of related products

- Series PD-10L: Differential pressure transducer with line pressure ≤ 200 bar
- Series PD-10LHPX: Pressure transducer PD-10LHP with digital compensation electronics
- Series 10L: Low-pressure transducer for absolute and relative pressure ranges ≤ 200 bar
- Series 10LHP: High-pressure transducer for absolute and relative pressure ranges > 200 bar
- Series 4L...9L: Low-pressure transducer in more compact designs for absolute and relative pressure ranges ≤ 200 bar



Series PD-10LHP – Analysis and Characteristic Lines

Standard Analysis

The pressure transducers are intended for O-ring mounting and are therefore designed for low transmission of forces. This installation enables the values measured in the test equipment to remain unchanged. If the transducers are not installed free from stress, the mechanical forces may change the measured values and the stability of the pressure transducers.

Calibration sheet: Example type PD-10L					Key
----- 4					<ol style="list-style-type: none"> Type (PD-10L) and measuring range (10 bar) of pressure sensor Serial number of pressure sensor Test temperatures Uncompensated zero offset Zero offset values with compensation resistor R1 (+) or R2 (-) connected Zero offset with calculated compensation resistors Temperature zero error with compensation resistors Compensation resistor values R1 or R2 (TCzero) and R3 or R4 (offset) RB: Bridge resistance at room temperature Offset with compensation resistors R1 or R2 and R3 or R4 Sensitivity of pressure sensor at room temperature Pressure test points Signal at pressure test points Non-linearity (best straight line through zero) Non-linearity (best straight line) Results of long-term stability Lot number and identification of silicon wafer Insulation test Excitation (constant current) Date of test ----- Test equipment
PD-10L / 10 bar / 10-1035-142⁽¹⁾ Sn 8447⁽²⁾					
⁽³⁾ Temp	⁽⁴⁾ Zero	⁽⁵⁾ +1000	⁽⁶⁾ Comp	⁽⁷⁾ dZero	
[°C]	[mV]	[mV]	[mV]	[mV]	
-9.3	3.5	1.1	1.1	-0.1	
-0.5	4.0	1.2	1.2	-0.1	
24.0	4.3	1.3	1.3	0.0	
49.3	4.8	1.3	1.3	0.1	
79.1	5.5	1.4	1.4	0.1	
----- 1					
COMP	R1	1000 kOhm ⁽⁸⁾	R3	0.0 Ohm ⁽⁸⁾	
RB	3425 Ohm ⁽⁹⁾				
ZERO	1.3 mV ⁽¹⁰⁾				
SENS	16.72 mV/bar⁽¹¹⁾				
LIN		⁽¹⁴⁾ Lnorm	⁽¹⁵⁾ LbfsI		
⁽¹²⁾ [bar]	⁽¹³⁾ [mV]	[%Fs]	[%Fs]		
0.000	0.0	0.00	-0.01		
2.500	41.8	0.02	0.01		
5.000	83.6	0.00	0.00		
7.500	125.4	-0.02	-0.01		
10.000	167.2	-0.01	-0.01		

Long Term Stability Ok ⁽¹⁶⁾					
Lot 72114-2 ⁽¹⁷⁾					
Test 500 Volt Ok ⁽¹⁸⁾					
Supply 1.000 mA⁽¹⁹⁾					
30.11.18 ⁽²⁰⁾ ----- PH02.A03D1S ⁽²⁰⁾					

Notes

- The indicated specifications apply only for constant current supply of 1 mA. The sensor must not be supplied more than 3 mA. The output voltage is proportional to the current supply (excitation). By using excitation unlike the calibrated excitation, the output signal can deviate from the calibrated values.
- If exposed to extreme temperatures, the compensation resistors should have a temperature coefficient of < 50 ppm/°C. Sensor and resistors can be exposed to different temperatures.
- Fine adjustment of zero with R5 potentiometer (20 Ω) is possible. In addition, a maximum TC-sensitivity can be guaranteed on request or the value for the compensation resistor (Rp) can be indicated. See Diagram "Measurement bridge with compensation" on page 1.

Characteristic Lines

Examples of typical characteristic lines of the temperature coefficients, normalised at 25 °C, pre-compensated with R1 or R2

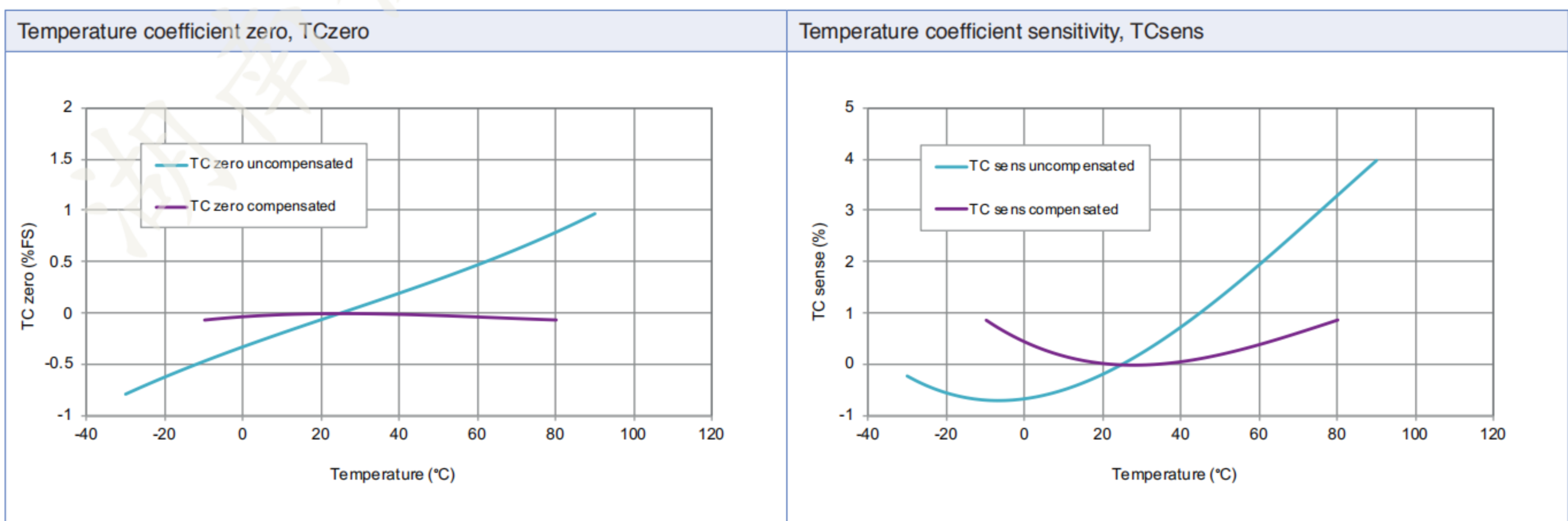



Series PD-10LHP – Analysis and Characteristic Lines

Mathematical Compensation Model

The KELLER pressure transducers of series PD-10LHP can be ordered with an optional mathematical compensation model.

The compensation model is a mathematical formula that helps to calculate the compensated pressure value of the pressure transducer.

Both the pressure signal and the temperature signal of the pressure transducer are incorporated into the calculation. Polynomial functions are used as the basis for this mathematical model.

The pressure transducers are characterised in the factory in order to produce the compensation model. This involves measuring pressure and temperature signals at various pressure and temperature levels. Comparing the measured values with the known pressure and temperature values enables the calculation of the compensation coefficients of the pressure transducer. These compensation coefficients are made available to the customer along with the respective pressure transducer.

湖南优谦测控科技有限公司